

DIE NO : 1998/SB	MATERIAL REF : WS.55.1	HARDNESS : 55°SH	DIE NO : 1911/SB	MATERIAL REF : WS.60.1	HARDNESS : 60°SH
------------------	------------------------	------------------	------------------	------------------------	------------------

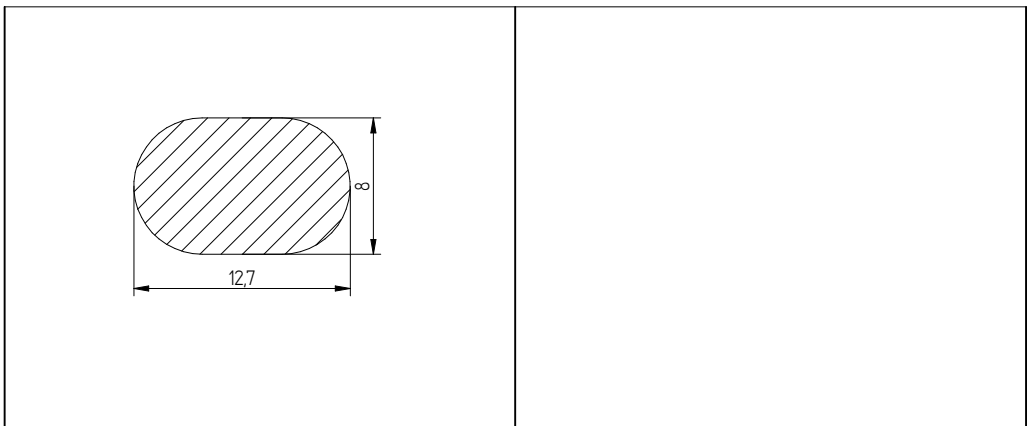

DIE NO : 1897/SB	MATERIAL REF : WS.60.1	HARDNESS : 60°SH	DIE NO :	MATERIAL REF :	HARDNESS : °SH
------------------	------------------------	------------------	----------	----------------	----------------

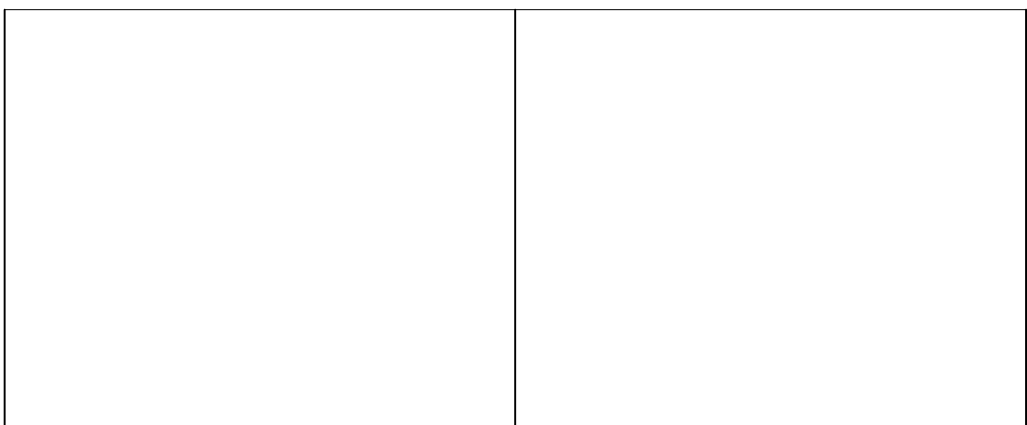

DIE NO :	MATERIAL REF :	HARDNESS : °SH	DIE NO :	MATERIAL REF :	HARDNESS : °SH
----------	----------------	----------------	----------	----------------	----------------