

DIE NO : 1946/SB

MATERIAL REF : WS.55.1

HARDNESS : 55°SH

DIE NO : 3461/SB

MATERIAL REF : WS.70.1

HARDNESS : 70°SH

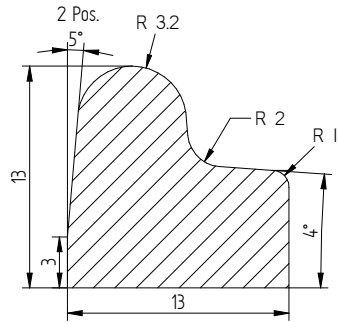

DIE NO : 3460/SB

MATERIAL REF : WS.70.1

HARDNESS : 90°SH

DIE NO :

MATERIAL REF :

HARDNESS : °SH

DIE NO :

MATERIAL REF :

HARDNESS : °SH

DIE NO :

MATERIAL REF :

HARDNESS : °SH